

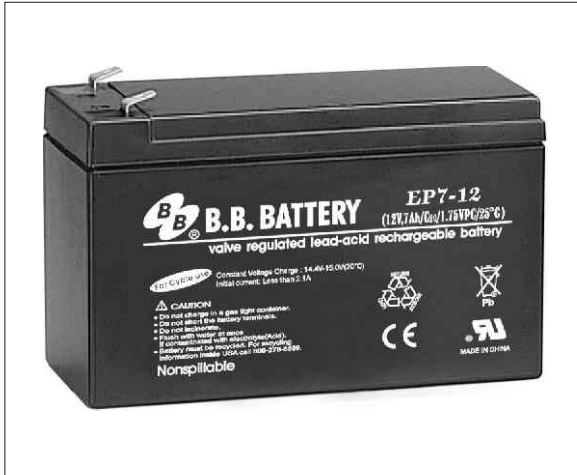

# Valve Regulated Lead-Acid Rechargeable Battery



## EP7-12

The battery is constructed by plates, separators, safety valves and container. Since the electrolyte is held by a glass-mat separator and plates, the battery can be used in any direction and position without leakage.

### PERFORMANCE SPECIFICATIONS

Nominal Voltage(V).....	12 volts(6cells in series)
Nominal Capacity(Ah)	
20 Hour rate F.V.(1.75V/cell) (350mA to 10.50volts) .....	7.0Ah
10 Hour rate F.V.(1.75V/cell) (665mA to 10.50volts) .....	6.65Ah
5 Hour rate F.V.(1.75V/cell) (1190mA to 10.50volts) .....	5.95Ah
30 Min rate F.V.(1.30V/cell) (7000mA to 7.80volts).....	3.50Ah
Approximate Weight.....	2600g(5.73lbs.)
Terminal	
Standard.....	Type T2
Optional.....	Type T1
Internal Resistance (Fully Charged Battery).....	<25m Ω
Maximum Discharge Current For 5 sec.(A).....	105A
Maximum Charge Current(A).....	2.1A
Ambient Temperature	
Charge.....	0°C(32°F)~40°C(104°F)
Discharge.....	-20°C(-4°F)~50°C(122°F)
Storage.....	-20°C(-4°F)~40°C(104°F)
Vibration test:	
Frequency: 16.7Hz	
Amplitude: 4mm	
vibrate the battery horizontally or vertically for 60 minutes. The battery have no abnormality.	
Case.....	ABS
Dimension(mm/inch)	
Length           ±1.5mm.....	151/5.94
Width           ±1.5mm.....	65/2.56
Container Height ±1.5mm.....	93/3.66
Total Height   ±2mm.....	98/3.86
Application.....	Laboratory Equipment, Toy-Cars, Power Packs, Fishing Lights.

## EP7-12 Battery discharge characteristics (25 °C/77 °F)

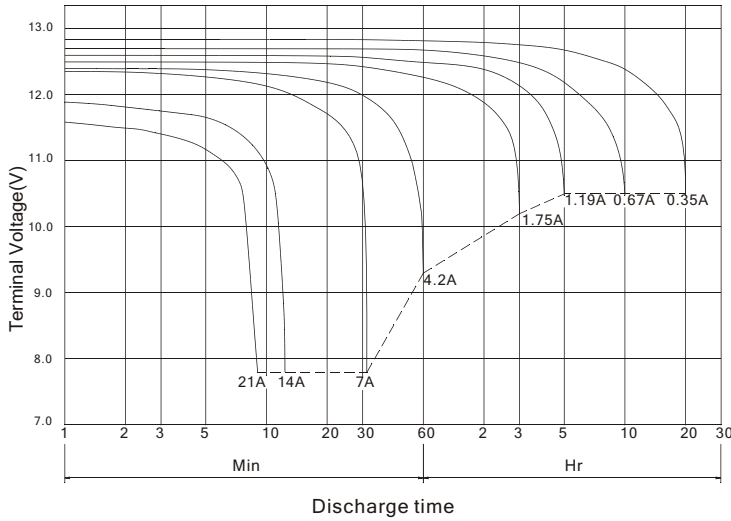

## BATTERY CHARGING CHARACTERISTICS

(Typical example of the charge characteristics for the cycle use)

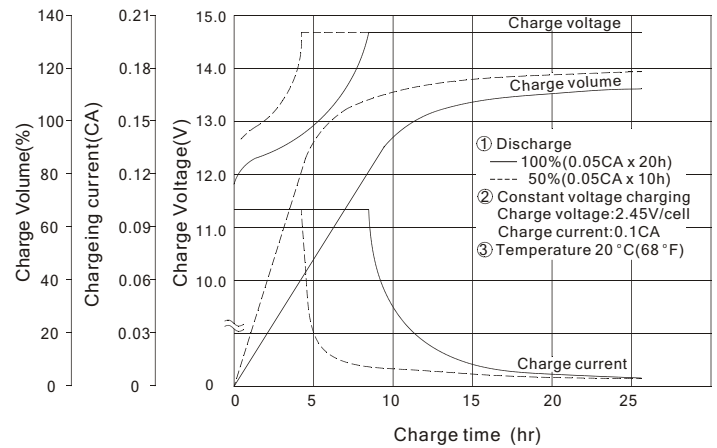

## Charging Procedure

Application	Charging method	Charging Voltage at 20 °C (V/cell)	Temperature compensation coefficient of charging voltage (mV/°C/cell)	Max. charging current (CA)	Charging time 0.1CA, 20 °C (h)		Temp (°C) 0~40 (32-104°F)
					100% discharge	50% discharge	
For standby power Source	Constant voltage & Constant current charging (with current restriction)	2.25~2.30	-3	0.3	24	20	
For cycle service		2.40~2.50	-4	0.3	16	10	

## Battery Life Characteristics of Cyclic Use

Testing Conditions : Discharge Current : 0.25C Amp(F.V. 1.7V/cell)  
 Charging Current : 0.1C Amp  
 Charging Volume : 120% OF Discharge Capacity  
 Ambient Temperature : 20 °C(68 °F)

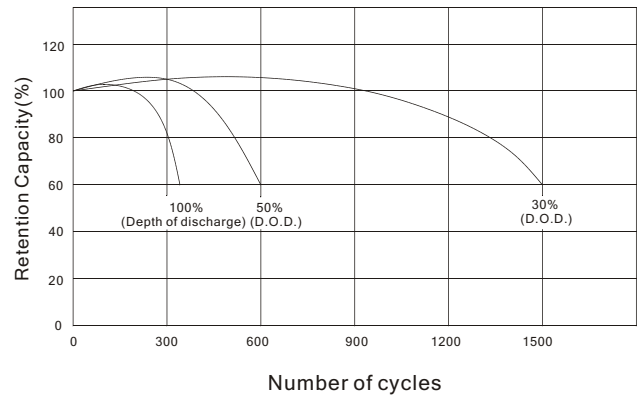

## TERMINAL TYPE

mm(inch)

### OUTER DIMENSIONS

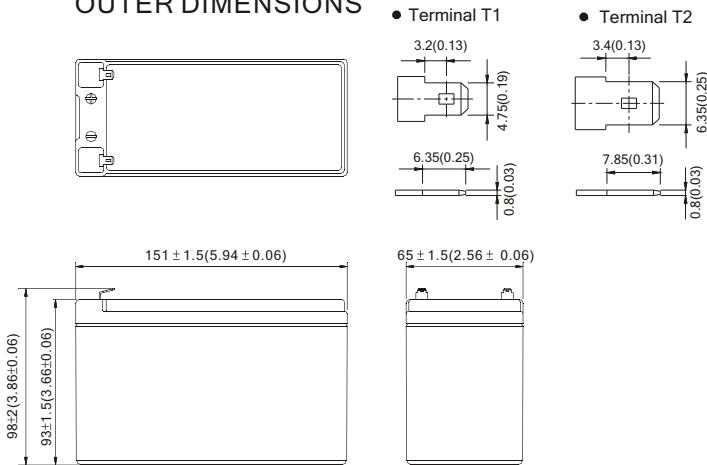

## Constant power discharge characteristics at 25°C/77°F

Final Voltage	Discharge time								
	5Min	10Min	15Min	30Min	1Hr	3Hr	5Hr	10Hr	20Hr
10.80V	228	171.4	138.8	83.5	48.4	20.4	14.1	7.86	4.11
10.50V	264	185.7	145.3	86.7	49.8	20.8	14.3	7.98	4.20
10.20V	280	192.4	149.7	88.6	50.7	21.0	14.4	8.02	4.22
9.90V	293	197.0	153.2	89.9	51.4	21.2	14.5	8.04	4.23
9.60V	302	200.9	156.2	90.8	51.9	21.3	14.5	8.04	4.23

## TERMINAL POSITION

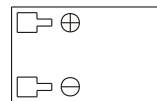

**B.B. BATTERY CO., LTD.**

Web Site: <http://www.bb-battery.com>

**USA:**  
 B&B BATTERY(USA) INC.  
 6415 RANDOLPH ST.COMMERCE,  
 CA,90040 U.S.A.  
 TEL:1-323-278-1900.1-800-278-8599  
 FAX:1-323-278-1268  
 E-Mail:sales@bb-battery.com

**EUROPE:**  
 B&B BATTERY(EUROPE) B.V.  
 3 WIJNGAARDVELD, 9300 AALST,BELGIUM  
 TEL:(00)32-53781567  
 FAX:(00)32-53781567  
 E-Mail:hansdevriese@bb-battery.com

**CHINA FACTORY:**  
 B.B. BATTERY CO., LTD.  
 CHENG DONG TRIAL AREA,HUANG GANG,  
 RAOPING, GUANG DONG,CHINA,515700  
 TEL:86-768-7601001-2  
 FAX:86-768-7601469  
 E-Mail:maggy@bb-battery.com

**HONG KONG:**  
 NATIONAL TRADING LTD.  
 TEL:852-2301-3800  
 FAX:852-2739-1182  
 E-Mail:bbhk@hkstar.com

**JAPAN:**  
 B&B BATTERY(JAPAN) CO., LTD.  
 1375-11 NARAHARA-MACHI,HACHIOJI,  
 TOKYO 193-0803,JAPAN.  
 TEL:81-426-25-6375  
 FAX:81-426-25-6375  
 E-Mail:miyata@bb-battery.com

**TAIWAN:**  
 B.B. BATTERY(TAIWAN) CO., LTD.  
 TEL:886-6-502-5150  
 FAX:886-6-589-8087  
 E-Mail:maggy@bb-battery.com

